

Binning Interface H0118

Manual

English



Important hints

Security

This instrument has been designed and tested in accordance with IEC Publication 1010-1, Safety requirements for electrical equipment for measurement, control, and laboratory use. It corresponds as well to the the CENELEC regulations EN 61010-1. All case and chassis parts are connected to the safety earth conductor. Corresponding to Safety Class 1 regulations (three-conductor AC power cable).

Do not disconnect the safety ground either inside or outside of the instrument!

The instrument must be disconnected and secured against unintentional operation, if you suppose that safe operation is not possible.

This may occur:

- if the instrument shows visible damage,
- if the instrument has loose parts.
- if the instrument does not function,
- after long storage under unfavourable circumstances (e.g. outdoors or in moist environments).

When removing or replacing the metal case, the instrument must be completely disconnected from the mains supply.

Warranty and Repair

HAMEG instruments are subjected to a rigorous quality control. Prior to shipment each instrument will be burnt in for 10 hours. Intermittent operation will produce nearly all early failures. After burn in, a final functional and quality test is performed to check all operating modes and fulfilment of specifications. The latter is performed with test equipment traceable to national measurement standards.

Statutory warranty regulations apply in the country where the HAMEG product was purchased. In case of complaints please contact the distributor who supplied your HAMEG product.

Binning Interface H0118

Introduction

The binning interface for the HM8118 allows the unit to operate with external hardware, which will physically sort components according to the measurement of the HM8118. Data lines for eight sorting BINs are provided, as well as control lines (ALARM, INDEX, EOM,TRIG).

Specification

Output signal:

Negative TRUE, open collector, opto-isolated, selectable pull-ups.

Measurement modes:

While the HM8118 is used for binning, the number of measurement modes is limited to the necessary modes for characterizing components.

These modes can be selected:

- R-Q: Resistance-Quality factor
- C-D: Capacitance-Dissipation factor
- L-Q: Inductance-Quality factor

Decision output:

- pass BINs:
BIN 0...5 for primary parameter
- fail BINs:
BIN 6 for secondary parameter
BIN 7 for general failure BIN
- Maximum current is 15 mA for output voltage of 1 V.

Index:

Analog measurement complete

Measurement complete:

Full measurement complete

Alarm:

Notification that an error was detected

External trigger:

Opto-isolated, selectable pull-up, pulse width > 10µs

The component sorting option is especially useful for production testing, component matching or other tests where similar components must be

compared to each others. The binning feature is an automatic process which simplifies the sorting eliminating the need to compare manually the parameters. A maximum of 9 binning configurations can be set using the store/recall feature. Binning configurations can also be operated using the remote interface. The HM8118 can sort components into as many as 8 separate BINs: six pass BINs, a secondary parameter BIN and a general failure BIN. At any given time only one BIN is activated.

The following table shows details for each BIN.

BIN	TYPE	Description
0..5	Pass BIN	Output BIN is activated when the measured value is within the user defined limit of the BIN. Sorting starts with BIN 0. If the value is outside the limits of BIN 0 the sorting is performed with the limits of BIN 1. This sequential process repeats, until the limits of BIN #5 are exceeded. If the value isn't within the limits of any enabled BINs the general failure BIN is activated.
6	Secondary parameter failure BIN	This BIN is used, if the primary value would be inside the BIN 0..5 range and only the secondary parameter exceeds the limit of BIN 6
7	General failure BIN	This BIN output is activated when the sorting doesn't fall into any of the 7 first BINs.

To enter binning parameters press the MENU key, then select the BIN option. In order to get access to the binning menu the handler interface board must be present.

BINNING:	ON
BIN NUMBER:	0
BIN:	OPEN
NOMINAL :	100.0
LOW LIMIT:	-4.0 %
HIGH LIMIT:	+5.0 %

BINNING ON/OFF

- ON: the binning feature is enabled.
- OFF: the binning feature is disabled.

BIN NUMBER

- Selection of the BIN number
- BIN 0 to BIN 5 correspond to the primary parameter pass BINs.
- BIN 6 corresponds to the secondary parameter failure BIN.
- There is no menu for the general failure BIN 7.

BIN OPEN or CLOSED

- OPEN: the corresponding BIN is enabled.
- CLOSED: the BIN is disabled.
- At least the first BIN 0 must be activated.

NOMINAL value of binning

- Enter the nominal value with the numerical keys and the unit entry key.
- The new nominal value including units will be displayed. There is no nominal value for BIN 6.

LOW LIMIT (Percentage of the low limit)

- There is only one limit for BIN 6, which is an absolute limit not a percentage.

HIGH LIMIT (Percentage of the high limit)

- The low limit is automatically adjusted to have a symmetrical low limit.
- If the limit must be asymmetrical, the high limit must be entered first, followed by the low limit.
- For symmetrical limits, enter only the high limit, the lower limit will be the negative of the upper limit.

Setup of the BINs

The HM8118 must be in manual function mode. Select the function corresponding to the parameter to be sorted. All functions as mentioned above in section „Measurement modes“ can be used.

Examples

PASS/FAIL for a resistor (1 k Ω \pm 1%, Q<0.0001)

1. Measure the resistor in automatic ranging mode, select RQ function.
2. Press AUTO/HOLD key to freeze the range. Press MENU and BIN. Turn on the binning feature.
3. Enter the nominal value (1.000 k) and 1.0 for the high limit value for BIN 0. Negative limit is automatically set to -1%. Open the BIN.
4. Select BIN 6 and enter the limit (0.0001). Open the BIN.

Make sure no other BINs are open.

- Parts that pass fall into BIN 0.
- Parts that fail for primary parameter fall into BIN 7.
- Parts that fail for secondary parameter fall into BIN 6.

Pin assignment

Pin No.	Signal Name	Description
1 2 4 6 21 17 18	COM	Common voltage
3	/EXT TRIG	External trigger: HM8118 is triggered on the falling edge of a pulse applied to this pin, when the trigger mode is set to External.
5	/ALARM	This signal is asserted when an error occurs (SRAM failure, code checksum error, calibration error, configuration not valid or ADC error)
7 19	EXT DCV2 EXT DCV2	External DC Voltage 2: DC voltage supply pin for DC isolated open collector outputs (/ALARM, /INDEX, /EOM). Maximum voltage is 30V, minimum 5V. DC Voltage supply pin for DC isolated LED input (/EXT TRIG).
8	/EOM	End of Measurement: This signal is asserted when the measurement data and comparison results are valid.
9	EXT DCV1	External DC Voltage 1: DC voltage supply pin for DC isolated open collector outputs (BIN0 to BIN7). Maximum voltage is 30V, minimum 5 V.
10	BIN7	Secondary parameter failure BIN
11	BIN5	Pass BIN #5
12	BIN3	Pass BIN #3
13	BIN1	Pass BIN #1
14	COM1	Common of BIN output opto-coupler emitters if jumper J3 [2-3] is present. Left open if emitters are connected to internal supply voltage (J3 [1-2] present)
15 16	COM2 COM2	Common of control lines output opto-coupler emitters if jumper J6 [2-3] is present. Left open if emitters are connected to internal supply voltage (J6 [1-2] present)
20	\INDEX	Index: This signal is asserted when an analog measurement is complete and the HM8118 is ready for next DUT to be connected to the unknown terminals. The measurement data, however, is not valid until the line /EOM is asserted.
22	BIN8	General failure BIN
23	BIN6	Pass BIN #6
24	BIN4	Pass BIN #4
25	BIN2	Pass BIN #2

Jumper assignment

Name	Location	Description
J1	1-2 2-3	Internal pull-ups (750 Ω) for BIN outputs are connected to pin 9 (EXT DCV1) Internal pull-ups are connected to internal isolated 5V power supply. Power supply common is connected to COM pin
S1		Pull-up enable. Enable or disable BIN pull-up
J3	1-2 2-3	BIN output opto-coupler emitters are connected to COM signal BIN output opto-coupler emitters are connected to COM1 signal
J5	Present not present	Limiting resistor of 190 Ω for /EXT TRIG input Limiting resistor of 1.2 kΩ for /EXT TRIG input
J6	1-2 2-3	Control lines output opto-coupler emitters are connected to COM signal Control lines output opto-coupler emitters are connected to COM2 signal
J7	1-2 2-3	Internal pull-ups (4k75) for control lines outputs are connected to EXT DCV2 signal. Internal pull-ups are connected to internal isolated 5V power supply.

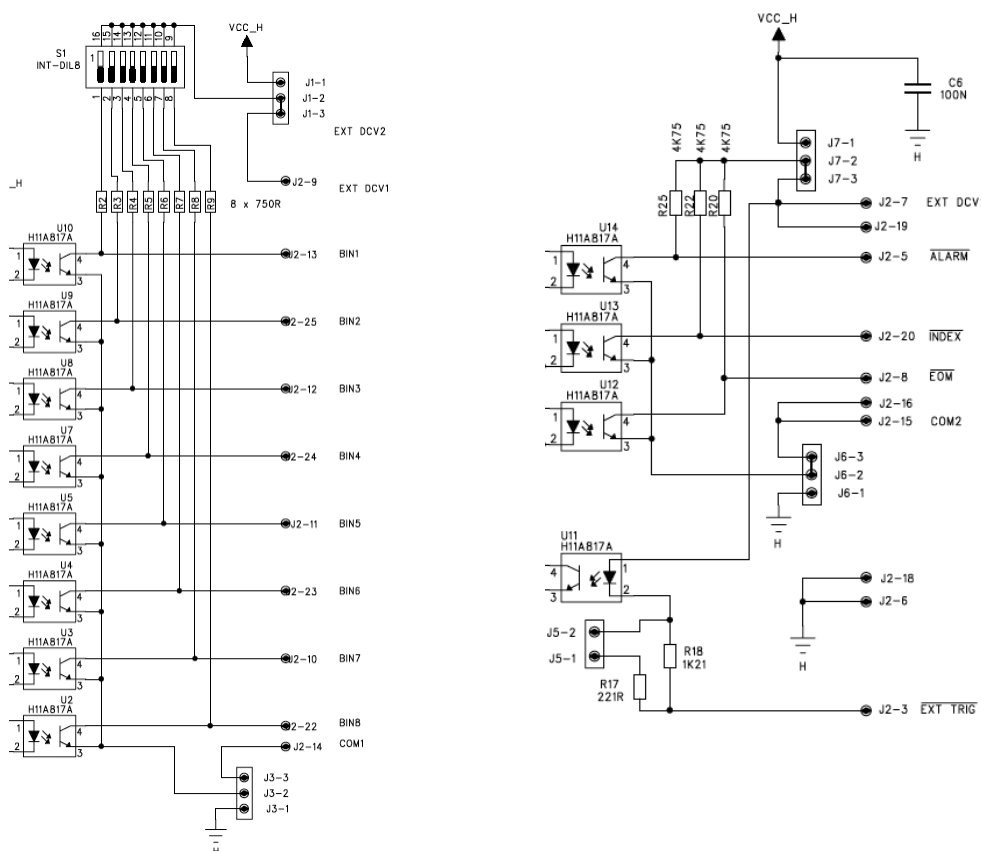

Connector for testing

D-SUB 25 male

Pin 13: Resistor 1k to cathode green LED

Pin 25: Resistor 1k to cathode green LED

Pin 10: Resistor 1k to cathode red LED

Pin 22: Resistor 1k to cathode red LED

Pin 9: Connected to the anodes of the four LEDs

Pin 3: Push button connected to pin 3

pass BIN 1

pass BIN 2

secondary parameter fall BIN

general fall BIN

start measurement

Jumpers:

J7: 1-2-3 shorted together

J6: 1-2

J5: 1-2

J3: 1-2

J1: 1-3

Instrument: select external trigger, manual function, manual ranging for better speed

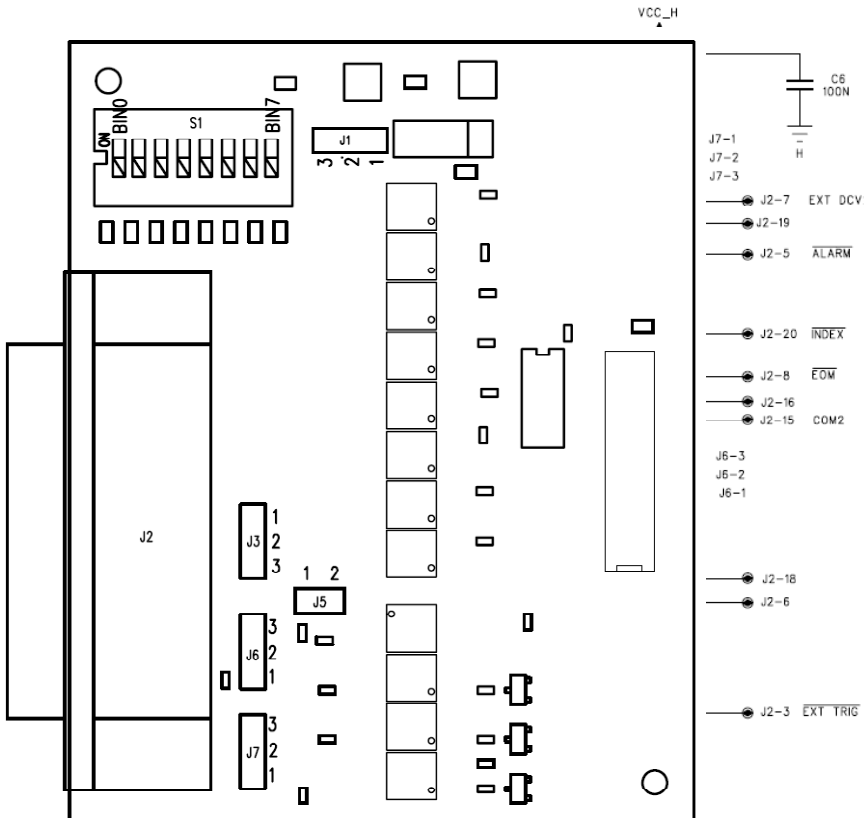

Oscilloscopes



Spectrum Analyzer



Power Supplies



Modular System
Series 8000



Programmable Instruments
Series 8100



authorized dealer

www.hameg.com

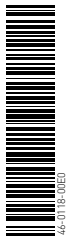

Subject to change without notice
46-0118-00E0 (0) 23022009

© HAMEG Instruments GmbH
A Rohde & Schwarz Company
® registered Trademark



DQS-Certification: DIN EN ISO 9001:2000
Reg.-Nr.: DE-071040 QM

HAMEG Instruments GmbH
Industriestraße 6
D-63533 Mainhausen
Tel +49 (0) 61 82 800-0
Fax +49 (0) 61 82 800-100
sales@hameg.de